

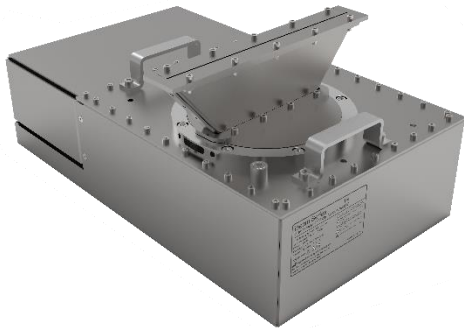

## RAXON160LPB



RAXON160LPB is an industrial X-ray source for producing a beam of high intensity X-rays with small focal spot and high stability which ensures uniform beam intensities and dose rate throughout its fan/cone-shaped beam. Stable voltage and electrical power applied to X-ray tube guarantees stable dose exposure and high-quality images in digital radiography systems.

### Applications

- Industrial Radiography
- Non-Destructive Testing
- Food Inspection
- Security Inspection
- Densitometry and Thickness Measurement

### Specifications

#### X-ray Characteristics:

Tube Type: Stationary anode, Glass tube,

Tungsten target, Be filter

Focal Spot: 0.8mm (IEC 336)

Beam Filter: 3mm thick 6061 Al,  $\pm 0.01$

Beam Geometry: Symmetrical fan up to 75° x 30°, cone up to 40°

#### Input Voltage:

220 $\pm$ 10%Vac, 50/60Hz, 1A maximum

#### X-ray Tube Voltage:

Nominal X-Ray tube voltage is adjustable between 80kV to 160kV with 10kV step.

#### X-ray Tube Current:

0.2mA to 1.2mA over specified tube voltage range

#### X-ray Tube Power:

200W, continuous mode

#### Voltage Regulation:

Line:  $\pm 0.1\%$  for a  $\pm 10\%$  input line change of nominal input line voltage

Load:  $\pm 0.1\%$  for a 0.2mA to 1.2mA load change

#### Voltage Accuracy:

Voltage measured across the X-ray tube is within  $\pm 2\%$  of the programmed value

#### Voltage Risetime:

Ramp time shall be <300ms from 10% to 90% of rated output

#### Voltage Overshoot:

Within 5% of rated voltage in <10ms

#### Voltage Ripple:

Up to 1% pp of rated voltage

#### Current Regulation:

Line:  $\pm 0.1\%$  for a  $\pm 10\%$  input line change of nominal input line voltage

Load: 0.5% @ 80-160kV, 0.2mA to 1.2mA

#### Current Accuracy:

Current measured through the X-ray tube is within  $\pm 5\%$  of the programmed value

#### Current Risetime:

<300ms from 10% to 90% of rated output

#### Arc Intervention:

4 arcs in 10 seconds with a 200ms quench = Shutdown

#### Filament Configuration:

Internal high frequency AC filament drive with closed loop filament emission control

#### Digital Interface:

RS-232/USB/Ethernet Interface selectable port

**Control Software:**

A demo GUI for engineering evaluations will be provided for the RS-232/USB/Ethernet digital interface and Encoded Command Port for customized software

**Emergency Stop:**

A physical emergency stop is embedded for prompt shut down in case of emergency independent of software and microcontroller modules

**Operating Temperature:**

0°C to +40°C

**Storage Temperature:**

-40°C to +70°C

**Humidity:**

10% to 95% relative humidity, non-condensing

**Tube Cooling:**

Oil circulation and cooling (Optional)

**Motherboard Cooling:**

Natural convection augmented by customer provided 250cfm cooling fans for continuous operation

**Input Power Line Connector:**

Standard 3pin Line-Null-Earth connector

**Dimensions:**

630mm X 355mm X 300mm

**Weight (Approx.):**

70 kg

**Installation Orientation:**

Can be mounted in any orientation.

**X-ray Leakage:**

Not to be greater than 5 $\mu$ Sv/hr at 5cm outside the external surface

**Accessories:**

RS-232/USB Connection cable  
Ethernet connection cable  
User Manual  
Software

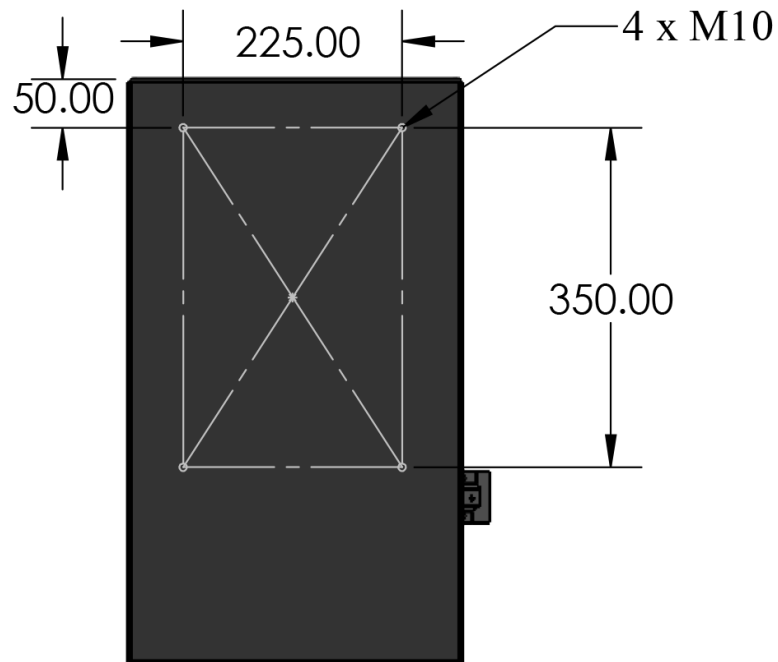
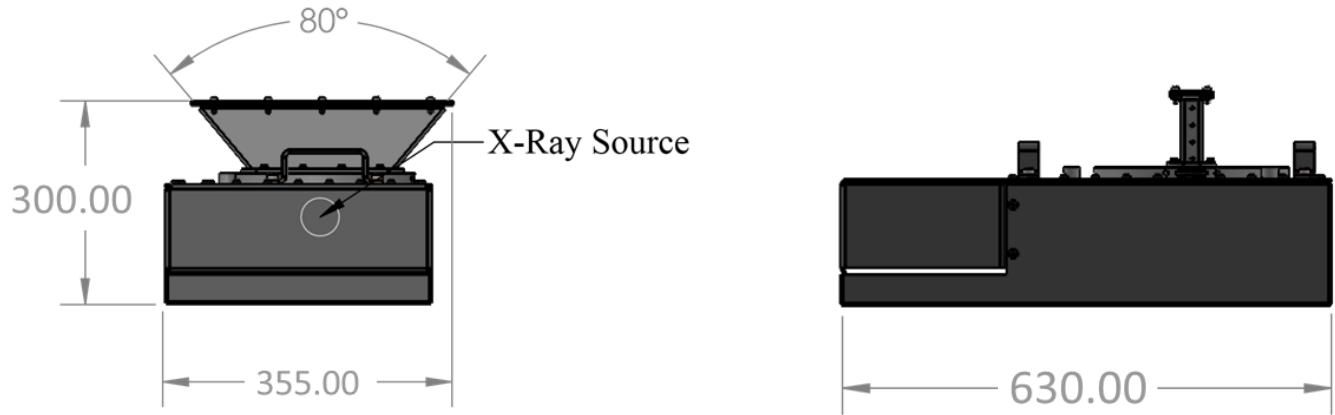

Dimensions are in millimeters